

- M8 Bolt
- M8 Hexagon nut
- M8 Spring lock washer
- M8 Hexagon nut, thin

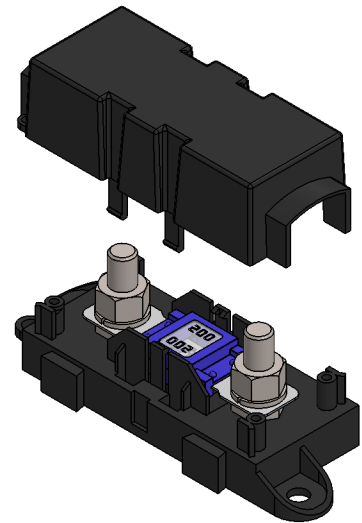
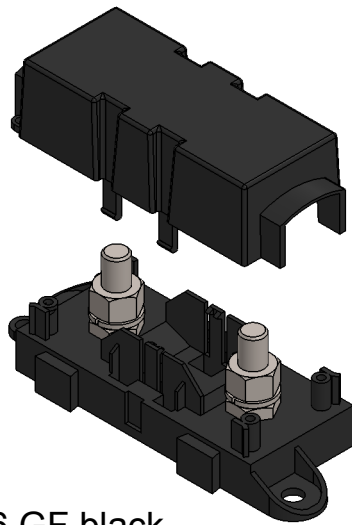

- A Holder body PA66 GF black
- B Two M8 studs, seled/protected in the mputing plate
- C Nut mounting torque 7-9 Nm

ELED ref.	Description
HMG1	MEGA fuse holder with cover

UNLESS OTHERWISE SPECIFIED:
 DIMENSIONS ARE IN MILLIMETERS
 SURFACE FINISH:
 TOLERANCES: 0,5
 LINEAR:
 ANGULAR:

DEBUR AND
 BREAK SHARP
 EDGES

DO NOT SCALE DRAWING

REVISION

ELED

	NAME	SIGNATURE	DATE	
DRAWN	B.D.		12.2014	
CHK'D				
APPV'D				
MFG				
Q.A				MATERIAL:
				WEIGHT:

TITLE:	MEGA fuse holder	
DWG NO.	HMG1	A4
SCALE:1:2	SHEET 1 OF 1	